

# RESU

## Installation Manual for RESU10H(Type-C)

Compatible Inverter: SMA Sunny Boy Storage

LG Chem strongly advises to take due care in following LGC's product installation manual. A warranty claim is invalid if damage is caused by human error, inconsistent with the installation manual.

Version 2.4



Scan the QR code  
[Installation Guide]



The information included in this manual is accurate at the time of publication. However, this manual is subject to change without prior notice. In addition, the illustrations in this manual are meant only to help explain system configuration concepts and installation instructions.

Please note the image shown is for illustration purposes only.

# Contents

<b>1</b>	<b>Safety</b>	<b>5</b>
1.1	Symbols.....	5
1.2	Safety Instructions.....	6
1.2.1	General Safety Precautions .....	6
1.2.2	Battery Handling Guide .....	6
1.2.3	Response to Emergency Situations .....	8
1.3	Warning label.....	9
1.4	Qualified Personnel.....	10
<b>2</b>	<b>Product Introduction</b>	<b>11</b>
2.1	Technical Data .....	11
2.1.1	Dimensions and weight .....	11
2.1.2	Performance.....	12
2.2	Feature.....	13
2.3	Packaging specification .....	13
<b>3</b>	<b>Installation</b>	<b>14</b>
3.1	Mechanical requirements.....	14
3.1.1	Unboxing the package .....	14
3.1.2	Items in the package.....	16
3.1.3	Installation locations .....	16
3.1.4	Clearance .....	17
3.1.5	Tools & Safety gears required.....	17
3.1.6	Mounting Bracket.....	19
3.1.7	Appearance and Dimension .....	20
3.1.8	System clearance .....	20
3.1.9	Installing the Battery Pack.....	21
3.2	Cable Connection.....	26
3.2.1	Spring terminal blocks .....	26

## Contents

<b>4</b>	<b>Commissioning</b>	<b>27</b>
4.1	LED indicators.....	27
4.2	Powering up the battery pack .....	28
4.3	Shutting off the battery pack .....	28
<b>5</b>	<b>Troubleshooting</b>	<b>29</b>
5.1	Troubleshooting .....	29
5.1.1	Post-Installation Check List .....	30
5.1.2	Troubleshooting Guideline.....	30
<b>6</b>	<b>Uninstallation &amp; Return</b>	<b>32</b>
6.1	Return/replacement instructions .....	32
6.1.1	Uninstallation from the wall .....	32
6.1.2	Contact information .....	34
<b>7</b>	<b>Maintenance</b>	<b>34</b>

# 1 Safety

## 1.1 Symbols



Caution, risk of electric shock



Do not place nor install near flammable or explosive materials.



Install the product out of reach of children.



Read the instruction manual before starting installation and operation.



Heavy weight may cause serious injury to the back.



Do not dispose of the product with household wastes.



Recyclable



Disconnect the equipment before carrying out maintenance or repair.



Observe precautions for handling electrostatic discharge sensitive devices.



Protective Class 1



Caution, risk of electric shock, energy storage timed discharge.

## 1.2 Safety Instructions

For safety reasons, installers are responsible for familiarizing themselves with the contents of this document and all warnings before performing installation.

### 1.2.1 General Safety Precautions

Over-voltages or wrong wiring can damage the RESU10H(hereinafter “battery pack”) and cause deflagration, which can be extremely dangerous.

All types of breakdown of the product may lead to a leakage of electrolyte or flammable gas.

Avoid installing the battery pack where flammable materials are stored. Do not install in places where explosive gas or chemicals are present.

During installation of the battery, the utility grid, solar input must be disconnected from the Battery Pack wiring. Wiring must be carried out by a qualified personnel.

Battery Pack is not user serviceable. High voltage is present in the device.

The electronics inside the Battery Pack are vulnerable to electrostatic discharge.

Be sure to be grounded before handling the battery pack.

Read the label with Warning Symbols and Precautions, which is visibly under to the Battery Cover (see Section 1.3)

### 1.2.2 Battery Handling Guide

- Store the product out of reach of children and animals.
- Store the product where it should be minimal dust and dirt in the area.
- Store at cool and dry place. (Do not store in greenhouses and storage areas for hay, straw, chaff, animal feed, fertilizers, vegetables of fruit products.)
- Store the product on a flat surface.
- Do not store this product in a place exposed to direct sunlight.
- Do not store the battery pack upside down on the ground.
- If the battery pack is installed in the garage then ensure the product is above the height of the vehicle bumper and/or door.
- Do not connect the power cables at terminal block opposite direction.
- Do not put the battery pack upside down on the ground.
- Do not expose battery to open flame.
- Do not expose or place near water sources like downspouts or sprinklers.
- Do not place the product nearby highly flammable materials. It may lead to fire or explosion in case of accident.

- Do not disconnect, disassemble or repair by unqualified personnel. Services must be made by qualified personnel only.
- Do not step on the product or the product package. The product may be damaged.
- Do not place any foreign objects on the top of the Battery Pack and on the cooling fin.
- Do not charge or discharge damaged battery.
- Do not connect any AC conductors or Photo-voltaic conductors directly to the battery pack and should be only connected to the Inverter.
- The RESU battery pack has been certified IP55 and can be installed indoors as well as outdoors. However, if installed outdoors, do not allow the battery pack to be exposed to direct sunlight and water source as it may cause :
  - Power limitation phenomena in the battery (with a resulting decreased energy production by the system)
  - Premature wear of the electrical/electromechanical components and mechanical components.
  - Reduction in performance, service life and possible damage of the battery
- A ventilated area is strongly recommended for handling the product.
- Only use the product with a LGC-authorized inverter. For a list of compatible inverters, go to : <http://www.lgesspartner.com>
- Do not touch if liquid is spilled on the product. There is a risk of electric shock. Handle the battery wearing the insulated gloves.
- Do not damage the unit in such ways as dropping, deforming, impacting, cutting or penetrating with a sharp object. It may cause a leakage of electrolyte or fire.

### 1.2.3 Response to Emergency Situations

The RESU10H battery pack comprises multiple batteries that are designed to prevent hazards resulting from failures. However, LG Chem cannot guarantee their absolute safety.

- If a user happens to be exposed to internal materials of the battery cell due to damage on the outer casing, the following actions are recommended.

Inhalation : Leave the contaminated area immediately and seek medical attention.

Eye contact : Rinse eyes with running water for 15 minutes and seek medical attention.

Contact with skin : Wash the contacted area with soap thoroughly and seek medical attention.

Ingestion : Induce vomiting and seek medical attention.

If a fire breaks out in the place where the battery pack is installed, perform the following countermeasures :

- **Fire Extinguishing Media**

Respirator is not required during normal operations.

Use FM-200 or CO2 extinguisher for battery fire.

Use an ABC fire extinguisher, if the fire is not from battery and not spread to it yet.

- **Fire Fighting Instructions**

1. If fire occurs when charging batteries, if it is safe to do so, disconnect the battery pack circuit breaker to shut off the power to charge.

2. If the battery pack is not on fire yet, extinguish the fire before the battery pack catches fire.

3. If the battery pack is on fire, do not try to extinguish but evacuate people immediately.

 **WARNING**

There may be a possible explosion when batteries are heated above 150°C.

When the battery pack is burning, it leaks poisonous gases, Do not approach.

- **Effective Ways to Deal with Accidents**

On land : Place damaged battery into a segregated place and call local fire department or service engineer.

In water : Stay out of the water and don't touch anything if any part of the battery, inverter, or wiring is submerged.

Do not use submerged battery again and contact the service engineer.



### 1.3 Warning label

Warning labels and other relevant labels are attached to the inside of the battery pack.

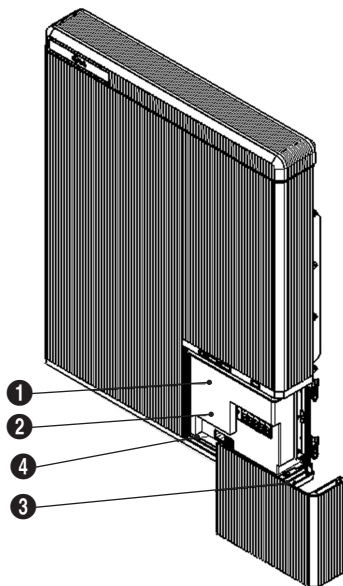

## 1. Warning Label

<b>⚠️ ⚡ DANGER / HIGH VOLTAGE INSIDE</b>			
<p>Do not disassemble or repair to avoid injuries, electric shock or burns. Service by authorized personnel only. Do not charge or discharge arbitrarily. If any leads to fault, electric shock or burns. Do not damage the unit in such ways as drop, deform, impact, cut or spear with a sharp object it may cause electrolyte leakage. Measure DC voltage before working in wiring box. <b>WARNING:</b> Battery system is a bidirectional source of voltage. Battery circuit breaker, and inverter must both be off, before working in the wiring box.</p>	<p>Do not attempt to break open the unit. The units are only serviceable by certified personnel. Do not place near open flames or incinerators. Keep out of reach of children or animals. Do not install this product in the place exposed to the direct sunlight. Sometimes even if the DC Disconnect is OFF, there may be voltage on the lines to the inverter. So please ensure the DC Disconnect on the inverter is also OFF during service/maintenance. Single person lift could cause injury. Use assistance when moving or lifting. Electric shock hazard if the ground fault is indicated. Normally grounded conductors may be Ungrounded and energized.</p>	<p>Verboten zu zerlegen oder zu reparieren, um Verletzungen wie Stromschlag oder Brände zu vermeiden. Nur geschultes Fachpersonal darf betriebsfertig. Verboten zu laden oder entladen. Es ist verboten, die Batterie willkürlich zu beschädigen. Schäden an der Einheit wie Herabwerfen, Verformung, Beschädigung, Durchstoßen mit scharfen Gegenständen sind zu vermeiden. Es ist verboten, die Batterie mit einem scharfen Gegenstand zu beschädigen. Messen Sie vor dem DC-Spannungsmessvorgang die Spannung an. <b>Warnung:</b> Das Batteriesystem ist eine bidirektionale Spannungsquelle. Batterie-Freischalter und Wechselrichter müssen abgeschaltet sein bevor Sie an der Batterie arbeiten werden.</p>	<p>Versuchen Sie nicht die Batterie aufzubrechen. Die Geräte sind nur durch zertifiziertes Personal bedienbar. Platzieren Sie die Batterie nicht in der Nähe von offenen Flammen oder Zündquellen. Halten Sie Kinder und Tiere fern. Installieren Sie die Batterie nicht in Umgebungen wo sie direktem Sonnenlicht ausgesetzt ist. Es kann vorkommen, dass selbst in ausgeschalteten Zustand des Speichers eine Spannung zwischen Batterie und Wechselrichter messbar ist. Auch wenn die DC-Transfer der Wechselrichters ist auch ausgeschaltet während Wartungen oder Servicearbeiten durchgeführt werden. Einzelne Personen können sich beim Anheben des Speichers verletzen. Holen Sie sich Hilfe, wenn sie den Speicher versetzen oder anheben müssen. Es herrscht Stromschlaggefahr, wenn es zu einem Erdschluss kommen sollte. Es kann vorkommen, dass geerdete Leiter doch nicht geerdet werden und unter Strom stehen.</p>
<p>Ne pas démanteler ou réparer pour éviter des blessures, chocs électrochocs ou brûlures. Seul un personnel de dépannage qualifié est autorisé à intervenir sur l'appareil. Ne pas charger et décharger arbitrairement. Contre l'impact et les défauts, chocs électrique ou brûlures. Ne pas endommager l'appareil par des chutes, déformations, impacts, coupures ou par des objets pointus. <b>Attention:</b> Ce système de batterie est une bidirectionnelle source de tension. Ce système de batterie doit être éteint avant de travailler sur le câblage.</p>	<p>ATTENTION: le système de la batterie est une source de tension bidirectionnelle. Le dépanneur ou l'expert de batterie et l'ondeleur doivent être hors tension avant câblage. Ne pas déposer près d'une flamme ou source de feu. Tenir hors de portée des enfants ou animaux.</p>	<p>Ne pas installer le produit dans un endroit directement exposé au soleil. Parfois, même si le courant continu est coupé, il peut y avoir du courant dans les lignes de l'onduleur. Assurez-vous donc que l'onduleur est également hors tension avant de commencer les interventions de maintenance. Porter l'appareil seul présente un risque de blessure. Merci de demander une assistance pour porter ou déplacer l'appareil. Si un défaut de la terre est indiqué alors il y a risque de choc électrique. Dans ce cas il se peut que la mise à la terre ne fonctionne pas.</p>	

## 2. Product Label

<b>LG Chem</b>		
<p>Model: R15563P3SDLT1 Capacity: 15.5 kWh Voltage: 48V Power: 3.0 kW</p>	<p>Model: R15563P3SDLT1 Capacity: 15.5 kWh Voltage: 48V Power: 3.0 kW</p>	<p>Model: R15563P3SDLT1 Capacity: 15.5 kWh Voltage: 48V Power: 3.0 kW</p>
<p>R15563P3SDLT1 1610317001</p>		

## 3. Traceability Label

	<p>R15563P3SDLT1 1610317001</p>

## 4. DS Warning Label

<p><b>⚠️ Warning!</b></p> <p>Please follow the ON/OFF procedure.  <b>ON : 1. Disconnect switch ON → 2. Circuit breaker ON</b>  <b>OFF : 1. Circuit breaker OFF → 2. Disconnect switch OFF</b></p>
---

## **1.4 Qualified Personnel**

This guide and the tasks and procedures described herein are intended for use by skilled workers only. A skilled worker is defined as a trained and qualified electrician or installer who has all of the following skills and experience:

- Knowledge of the functional principles and operation of on-grid and off-grid (backup) systems.
- Knowledge of the dangers and risks associated with installing and using electrical devices and acceptable mitigation methods.
- Knowledge of the installation of electrical devices.
- Knowledge of and adherence to this guide and all safety precautions and best practices.

# 2 Product Introduction

## 2.1 Technical Data

### 2.1.1 Dimensions and weight

RESU10H (Type-C)	
P/N	EVEBPBO100A0
Width	744 mm (29.3")
Height	907 mm (35.7")
Depth	206 mm (8.1")
Weight <sup>1)</sup>	99.8kg (220lbs)

1) A battery pack's weight varies slightly.

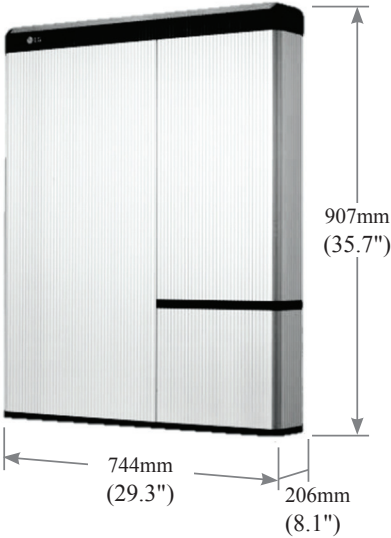

## 2.1.2 Performance

### RESU10H

Electrical Characteristics		
Total Energy Capacity	9.8kWh@25°C (77°F), 100% State of Energy	
Usable Energy Capacity <sup>1)</sup>	9.3kWh	
Battery Capacity	63 Ah	
Voltage Range	Charge	468 to 550 VDC
	Discharge	430 to 507 VDC
Absolute Max. Voltage	570VDC	
Max. Charge/Discharge Current	10.7A@467V / 11.7A@427V	
Max. Charge/Discharge Power <sup>2)</sup>	5kW	
Peak Power <sup>3)</sup> (only discharging)	7kW for 10 sec.	
Peak Current (only discharging)	16.3A@430V for 10 sec.	
Communication Interface	CAN	
DC Disconnect	Circuit Breaker	
Connection Method	Spring Type Connector	
User interface	LEDs for Normal and Fault operation	

Operating Conditions	
Installation Location	Indoor / Outdoor (Wall-Mounted)
Operating Temperature	14 to 113°F (-10 to 45°C)
Operating Temperature (Recommended)	59 to 86°F (15 to 30°C)
Storage Temperature	-22 to 131°F (-30 to 55°C)
Humidity	5% to 95%
Altitude	Max. 6,562ft (2,000m)
Cooling Strategy	Natural Convection
Noise Emission	< 40 dBA

Certification		
Safety	Cell	UL1642
	Battery Pack	UL1973 / CE(IEC 60950-1,62477-1) / RCM / TUV(IEC 62619)
Emissions	FCC	
Hazardous Materials Classification	Class 9	
Transportation	UN38.3	
Ingress Rating	IP55	

※ Test Conditions - Temperature 25°C, at the beginning of life.

※ Energy is measured under specific condition from LGC (0.3CCCV/0.3CC).

※ Short circuit Current: 496.5A

1) Value for Battery Cell Only(Depth of Discharge 95%).

Actual usable energy at the AC output may vary by condition, such as the battery converter, inverter efficiency and temperature.

2) LG Chem recommends 2.1kW for maximum battery lifetime.

3) Peak Current excludes repeated short duration(less than 5 sec. of current pattern).

## 2.2 Feature

- Compact Energy storage unit for domestic photovoltaic system compatibility
- Residential 400V DC battery pack system : Daily cycle residential battery system
- Additional Devices : Protection Devices\* Included
  - \* Protection Devices
    - Inverter interface (between Battery Pack and Inverter) : Over Voltage, Over Current, External Short Circuit, Reverse Polarity, Inrush Current, Ground Fault, Over Temp.
    - Battery inside (between Li-Ion battery and DC/DC converter) : Internal Short Circuit, Over Voltage, Over Current, Over Temp, Under Voltage
- Flexible installation : Indoor or Outdoor

## 2.3 Packaging specification

Category		Contents			
Size (L×W×H) (mm)		960 (37.8")	1,070 (42.2")	450 (17.7")	Outer Size
Qty/Box (ea)		1			1 piece × 2 layers
Packaging Materials	Box	Corrugated Cardboard			Disposable
	Inner	EPS			Disposable
	Pallet	Wood			Disposable
Weight (kg)	Product	102 (225lbs)			1 piece/Box (Battery + Package Items)
	Packaging	31 (68lbs)			Pallet + Box
	Gross	133 (293lbs)			Product + Packaging

# 3 Installation

## 3.1 Mechanical requirements

### 3.1.1 Unboxing the package

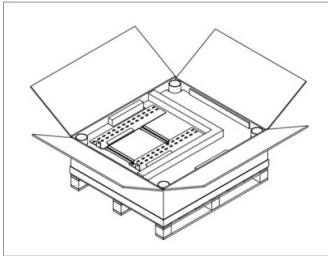

1. Cut the packing tape and open the carton.

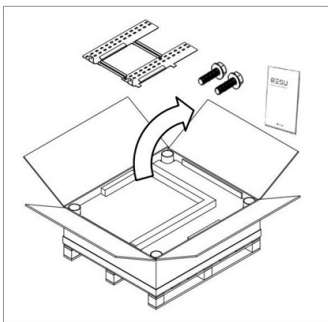

2. Pull out other items.  
Take them out and check if any item is missing.  
See Package items on section 3.1.2

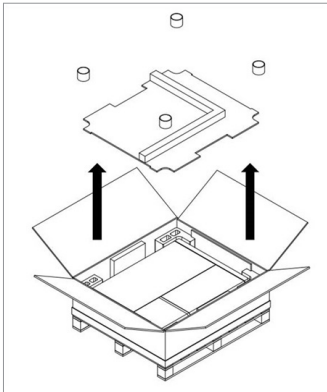

3. Remove the wall bracket guide pad & cushioning pad & paper pipes (4ea).

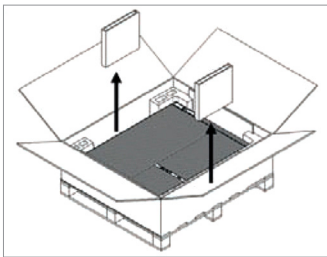

4. Remove the side pad.

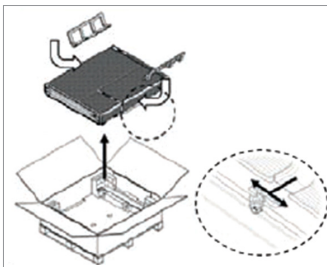

5. Pull out the battery pack using handles and stand it up. (Lift handles are sold separately for this product.)

**⚠ CAUTION**

According to regional regulations, several people may be required for moving equipment.

### 3.1.2 Items in the package

These items are included in the package.

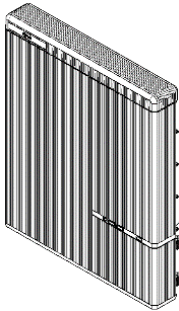

Battery pack

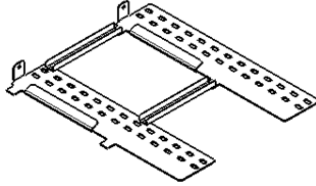

Wall bracket



M6 wall mount bolts (2EA)



Manual

### 3.1.3 Installation locations

#### Required :

- There must be no highly flammable or explosive materials nearby.
- The ambient temperature should be within the range of 14 ~ 113°F (-10 ~ 45°C).
- Battery pack must be installed on walls that are upright and can support battery weight.
- Product shall be installed indoors (ex. basement or garage); or, outdoor but must be installed under an eave and out of direct sunlight.

#### Recommended :

- The building should be designed to withstand earthquakes.
- The waterproof and properly ventilated area is recommended. (IP55)
- Install the product on a flat wall.
- Install this product out of reach of children and animals.

#### CAUTION

If the ambient temperature is outside the operating range, the battery pack stops operating to protect itself. The optimal temperature range for the battery pack to operating is from 59 to 86(15 to 30°C). Frequent exposure to harsh temperatures may deteriorate the performance and life of the battery pack.



### 3.1.4 Clearance

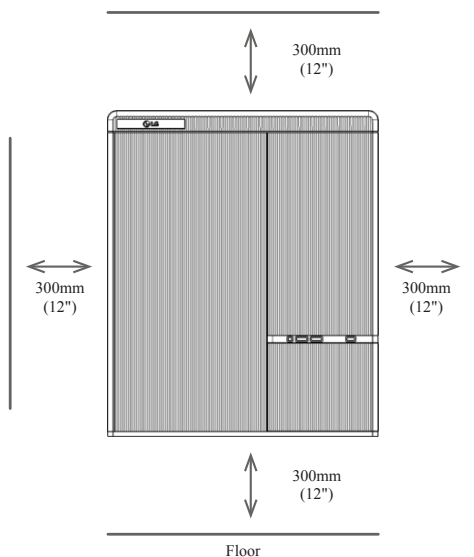

- Recommended clearances for the left, right, top and bottom of the product is shown in the figure for the proper ventilation and installer convenience.

### 3.1.5 Tools & Safety gears required

- **Tools**

The following tools are required to install the battery pack :

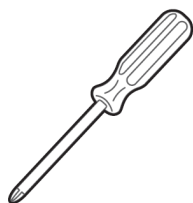

Precision screwdriver

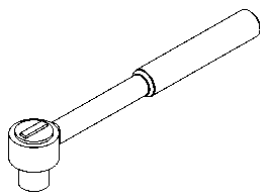

M6 Torque wrench

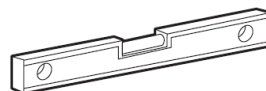

Inclinometer

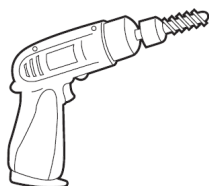

Drill  
(Min. Diameter 10mm, 0.4")



Pencil or Marker

- **Safety gears for personal protection**

It is recommended to wear the following safety gears when handling the battery pack.



Insulated gloves

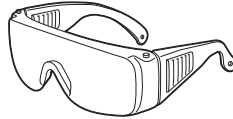

Safety goggles



Safety shoes

**NOTE**

RESU HV is heavy and challenging to lift. Lift handles are recommended.

### 3.1.6 Mounting Bracket

When installing the battery pack on a wall, make sure that the wall is capable of supporting the weight of the battery pack.

To mount the battery pack on a wall, take the following steps :

1. Mark the location on the wall for the holes.
2. Drill holes for fasteners in the wall.
3. Drive the fasteners through the mounting bracket into the holes.

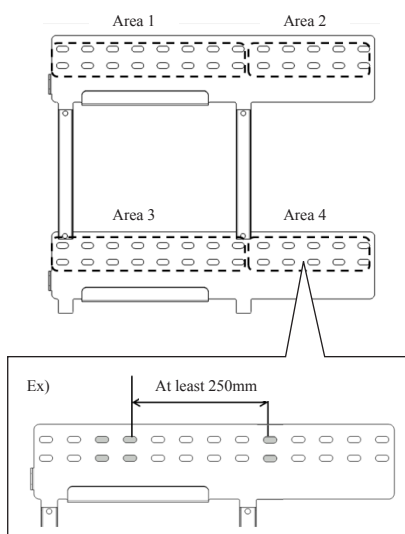

- Recommended diameter :  
10mm(0.4") Min.
- Recommended length :  
70mm(2.8") Min.
- Recommended material :  
Stainless steel (8.8T)
- Recommended fastener count :  
 $4(\text{Area1})/2(\text{Area2})/4(\text{Area3})/2(\text{Area4})$   
- Vertically
- Recommended minimum fastener clearance :  
At least 250mm (10")  
ex. Between Area 1's last fastener and  
Area 2's first fastener

#### CAUTION

Make sure that the battery pack is at all times exposed to the ambient air. The battery pack is cooled by natural convection. If the battery pack is entirely or partially covered or shielded, it may cause the battery pack to stop operating.

### 3.1.7 Appearance and Dimension

- **Appearance**

Proper handling and care is recommended as disassembly, change of color, scratches, leakage of liquid, and stains may influence the economic value of the battery pack.

- **Pack appearance and dimension**

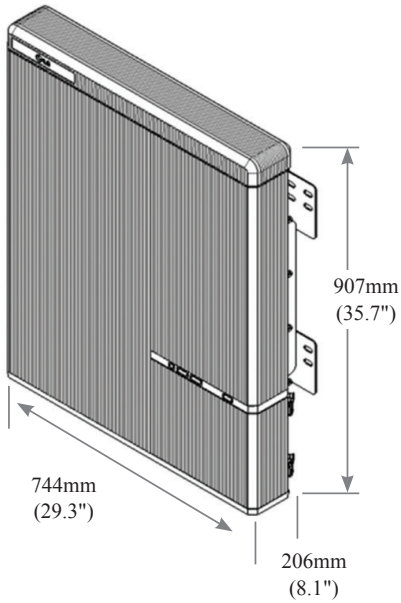

- **Color and Material**

- Front / Rear Cover : Silver or Gold, Aluminum
- Top / Bottom / LED Cover : Black, Plastic

### 3.1.8 System clearance

Battery requires adequate clearance for installation, cabling and air flow.

Minimum clearance in the system configuration is as follows. Cable connecting between battery pack and inverter makes sure the installation guide manual of the inverter.

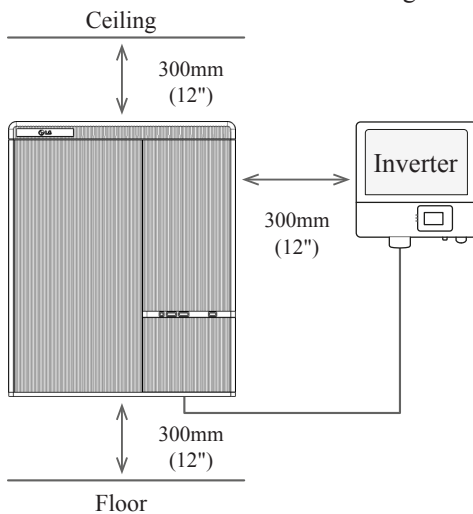

### 3.1.9 Installing the Battery Pack

#### CAUTION

Make sure that the inverter AC and DC disconnects are turned off before connecting the power cable to the battery pack.

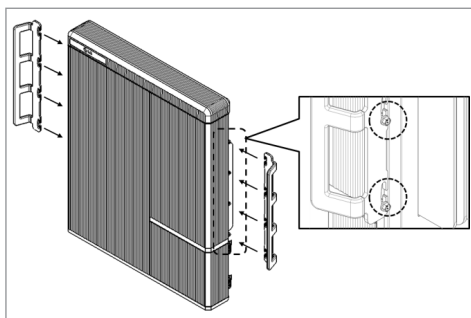

1. Fix the lift handles to the hex-socket screws on the rear (marked position) of both left and right sides.

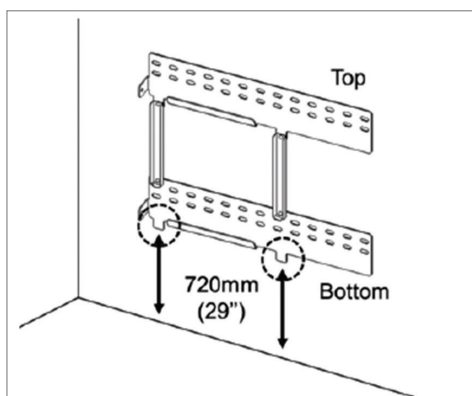

2. Mount the wall bracket to a wall. Tighten the screws, ensuring that they are horizontally driven into the wall. (Must be installed with recommended clearances(720mm[29"]) on the edge of the wall bracket as shown in the figure)

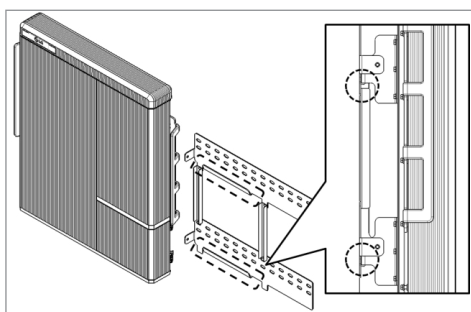

3. Mount the battery pack to a wall bracket's "U" shape clip using the support by lift handles. Remove the lift handles.

#### CAUTION

When installing the battery pack with lift handle, It is heavy to install around 100kg. Be sure to remove the obstacles from the surroundings and lift the battery pack with two people at the same time.

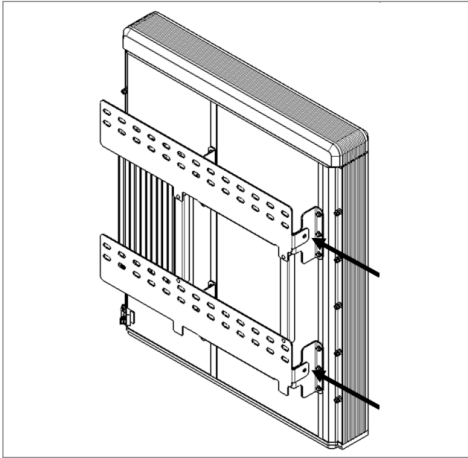

4. Tighten the two hex-socket screws enclosed and remove the lift handles. The nuts for these screws are welded to the battery pack chassis. Tighten to a torque of 5 N•m using the M6 torque wrench.

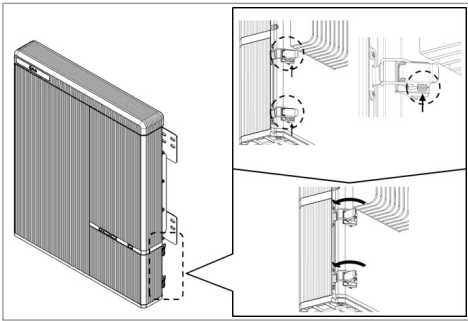

5. Press the two buttons and pull the two latches (marked position) on the rear side of the wiring box cover (hinged door).

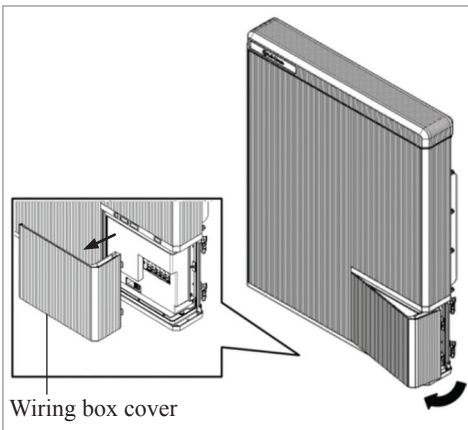

6. Open the wiring box cover (about 2~10 degrees), and pull to remove it.

**⚠ CAUTION**

The wiring box cover is heavy. [approx. 1.6kg(3.5lb)] If dropped it may cause injury.

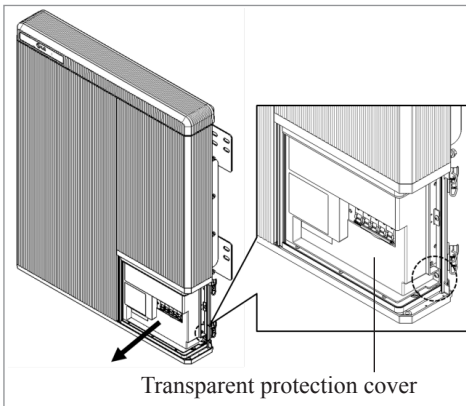

7. Loosen the screw (marked position), and remove the transparent protection cover.

**⚠ CAUTION**

If you lose or break a protection cover, that violates NEC Regulation.

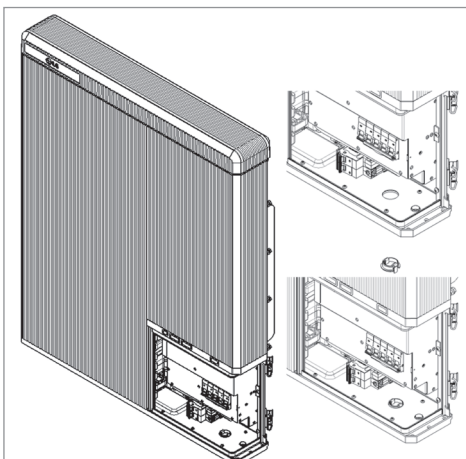

8. Remove the cap on hole in the bottom side, and assemble the 3/4" conduit plug. In the case outdoor, it must be sealed to comply "IP55" [ex] gasket, sealing foam, silicon, etc], where the battery pack installation is outdoor.

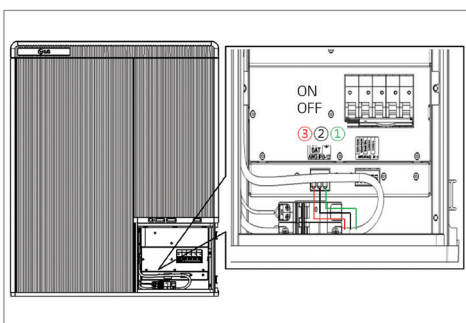

9. Connection Power / Communication cables, according to the labels marked.

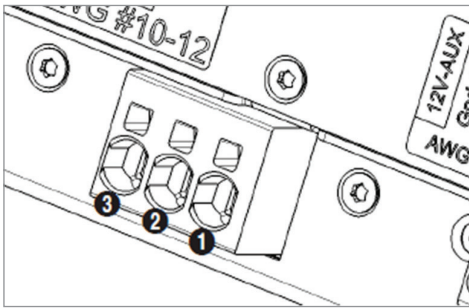

10. See 3.2.1. for Power Cable specifications

- a) Connect the ground wire to terminal 1.
- b) Connect the negative line of the power cable to terminal 2.
- c) Connect the positive line of the power cable to terminal 3.

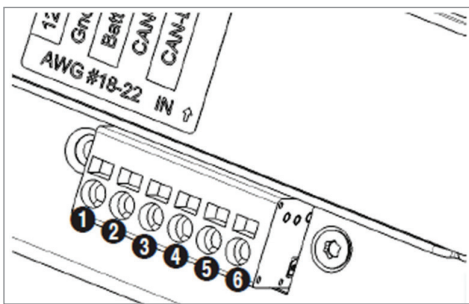

11. See 3.2.1. for Communication Cable specifications

At first, connect the ground wire to terminal 2. Then, make connections to the other terminals one after another except terminal 6. Leave terminal 6 unconnected.

Install protection cover before turning on.

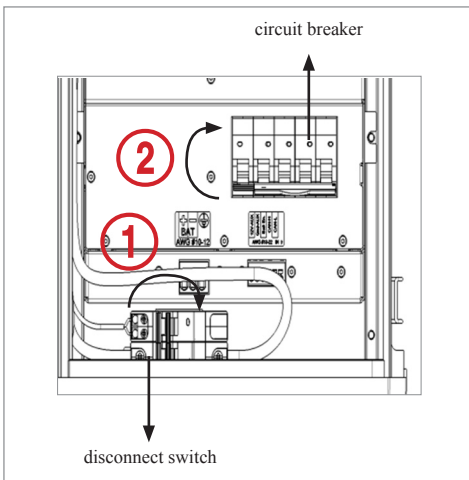

12. Connecting the battery pack to the inverter

Refer to the Installation Instructions

For the inverter to connect the power cable

And communication cable to the inverter.

Then, push the disconnect switch up

So that it is in the ON position.

13. After turning disconnect switch ON,

Turn on the circuit breaker.

(If you do not turn on the circuit breaker

within 60 seconds after turn on the

disconnect switch, then the disconnect

switch will trip.)

**⚠ CAUTION**

**MUST** follow the turn on procedure.



**⚠ CAUTION**

Please must do the switch on & off operation at the middle side of lever.  
 It's forbidden to do the operation at the left or right edge side of combined body.  
 Any wrong operation cause the products break off.

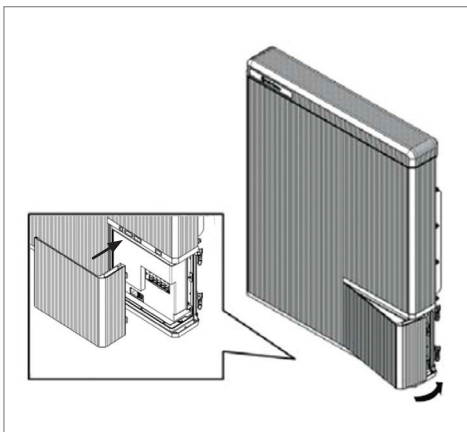
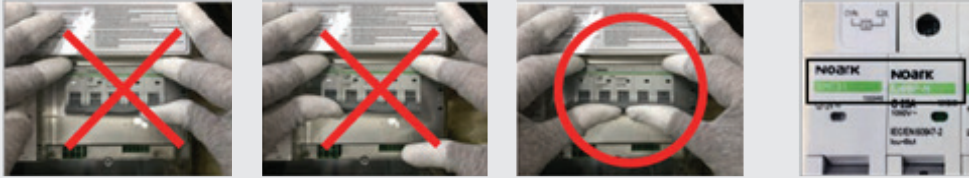

14. Reattach the transparent protection cover and tighten with the screw (Marked position)  
 Close the wiring box cover. Reattach battery over the two latchets on the rear.

**※ Connect/disconnect the wire to connector sequence**

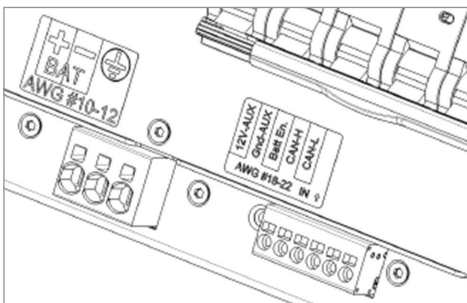

1. To remove one of the wires from its terminal, insert a small screwdriver into the rectangular hall above the terminal.
2. Apply slight pressure to the screwdriver and at the same time pull out the wire.

## 3.2 Cable Connection

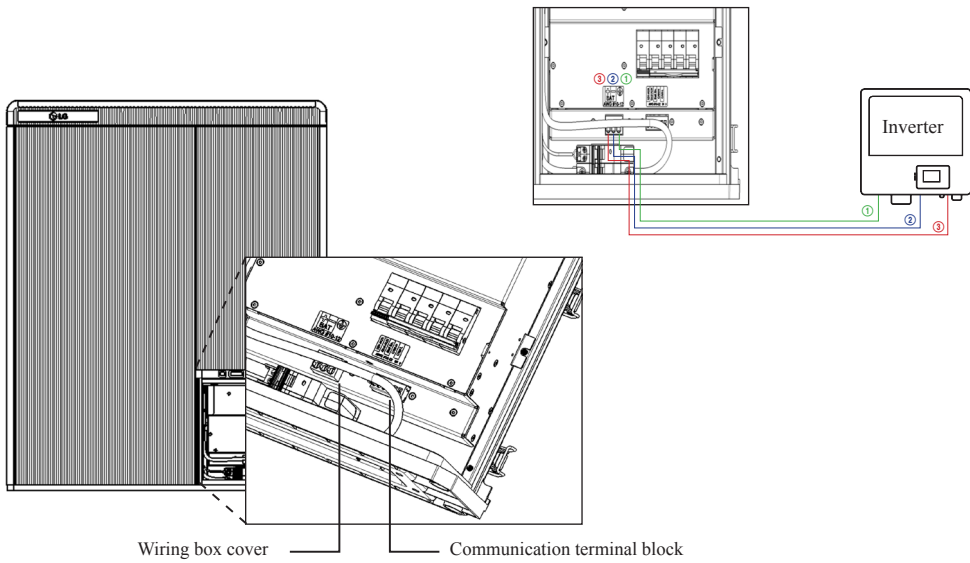

### 3.2.1 Spring terminal blocks

#### 1. Power terminal block

- Max cable length: 10m (35ft)
- Cable Type : 4~10mm<sup>2</sup> (10~12AWG)
- DC 600V insulated
- Pinning
- Phoenix Contact
- PCB Terminal Block SPT  
5/3-V-7,5-ZB
- P/N : 1719325

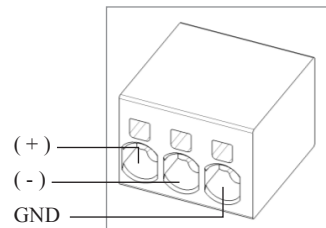

#### 2. Communication terminal block (SELV)

- Max cable length: 10m (35ft)
- Cable Type : 0.2~1.5mm<sup>2</sup>  
(18~22AWG)
- Pinning
- Phoenix Contact
- PCB Terminal Block SPT  
2,5/6-V-5,0
- P/N : 1991134

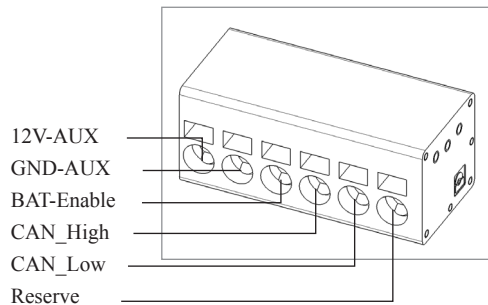



# 4 Commissioning

## 4.1 LED indicators

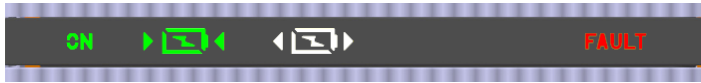
The LED indicators on the front of the battery pack show its operational state as follows:

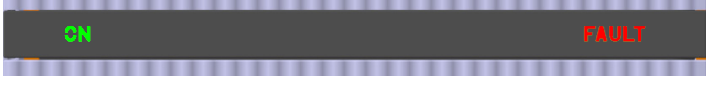

LED Status	Action
	Power on, Idle
	Charging
	Discharging
	Fault

There are four LED indicators on the front of the battery packs to show its operating status.

**ON** : This indicator stays on while the battery pack is ON.

**Charging** : This stays on while the battery pack is charging.

**Discharging** : This stays on while the battery pack is discharging.

**FAULT** : This comes on when the battery pack is in a warning state.

See Troubleshooting on page 29

## 4.2 Powering up the battery pack

Put the battery pack in operation by taking the following steps :

1. Remove the wiring cover box.
2. Make sure that the circuit breaker and Disconnect switch is in the OFF Position.
3. Move the Disconnect switch to the ON position to turn on the main battery pack.
4. Move the circuit breaker switch to the ON position within 60 seconds after turn on the Disconnect switch.
5. See if the battery pack is successfully initialized.  
The power on indicator on the front should turn on in green.
6. Close the wiring cover box.
7. Turn on the inverter.

## 4.3 Shutting off the battery pack

To shut down the battery pack, take the following steps :

1. Turn off the inverter.
2. Remove the wiring cover box.
3. Turn off the battery pack by moving the circuit breaker switch to the Off position.
4. Turn off the battery pack by moving the disconnect switch to the Off position.
5. Make sure that every indicator on the battery pack is off. It would take 60 seconds at maximum for the indicators to turn off.
6. Close the wiring cover box.



### **WARNING**

Do not turn off the disconnect switch at normal operation (Charge/Discharge/Idle).  
If not commissioning after installation or there is any fault on the battery pack, turn off the Circuit Breaker, then turn off the disconnect switch.

# 5 Troubleshooting

## 5.1 Troubleshooting

Check the indicators on the front to determine the state of the battery pack. A warning state is triggered when a condition, such as with voltage or temperature, is beyond design limitations. The battery pack's BMS periodically reports its operating state to the inverter.

When the battery pack falls outside prescribed limits, it enters a warning state.

When a warning is reported, the inverter immediately stops operation.

Use the monitoring software on the inverter to identify what caused the warning.

The possible warning messages are as follows:

- Battery Over Voltage
- Battery Under Voltage
- Battery Over Temperature
- Battery Under Temperature
- Battery Discharge Over Current
- Battery Charge Over Current
- BMS Internal Communication
- Battery Cell Voltage Imbalance

The abnormal state is cleared when the battery pack recovers normal operation.

If battery pack is not working correctly and the issue persists, contact a qualified personnel, Installer or LGC regional contact point.

### **NOTE**

For a serious warning, if no proper corrective actions are taken by the inverter, the battery pack's circuit breaker and disconnect switch automatically trip to protect it self.

### **CAUTION**

If the battery pack or the inverter indicates FAULT or fails to operate, contact LGC regional contact point(page 34) or your distributor immediately.

### 5.1.1 Post-Installation Check List

	Yes	No
1. Visual check if the wiring matches with the installation manual. (3.2 Cable connection)	<input type="radio"/>	<input type="radio"/>
2. The disconnect switch is ON.	<input type="radio"/>	<input type="radio"/>
3. The Circuit Breaker is ON.	<input type="radio"/>	<input type="radio"/>
4. The battery "ON" LED is ON.	<input type="radio"/>	<input type="radio"/>
5. The inverter power is ON. <sup>1)</sup>	<input type="radio"/>	<input type="radio"/>
6. The inverter has the latest firmware. <sup>2)</sup>	<input type="radio"/>	<input type="radio"/>
7. The inverter recognizes the battery.	<input type="radio"/>	<input type="radio"/>
8. The battery can operate after installation is correctly done. 8-1. The AC grid is connected. 8-2. The Meter is installed. 8-3. The government approval is complete.	<input type="radio"/>	<input type="radio"/>
9. IF ANY OF #8 IS CHECKED AS "NO" OR THE INVERTER NEEDS TO BE TURNED OFF,TURN OFF THE CIRCUIT BREAKER. <sup>3)</sup>	<input type="radio"/>	<input type="radio"/>

### 5.1.2 Troubleshooting Guideline



#### If the battery LED is OFF

1. Turn off the Circuit Breaker.
2. Turn off the disconnect switch.
3. Turn off the inverter. Verify there is no power at the battery connection.
4. Unplug all the wires and reconnect. Re-check the wiring on the battery is done correctly. Refer to the installation manual (3.2 Cable connection).
5. Turn on the Circuit breaker.
6. Turn on the inverter.
7. If the LED is still off, turn off the Circuit Breaker.
8. Contact LGC regional contact point.

- 
- 1) Contact the inverter manufacturer.
  - 2) Refer to the inverter installation manual or troubleshooting guideline.
  - 3) Refer to the User guide or Installation manual (3.2 Cable connection) for the location of the battery. (Circuit Breaker).

### If the battery LED is ON, but the battery is not charging or discharging

1. Update both the inverter and battery firmware version. Refer to the inverter's troubleshooting guide for instruction.
2. Check the inverter's setting for battery. Refer to the inverter's troubleshooting guide for the battery set-up instruction.
3. If the battery is recognized, inverter set up is correct.
4. If the issue persists,
  - 4-1. Turn off the Circuit Breaker.
  - 4-2. Turn off the disconnect switch.
  - 4-3. Turn off the inverter. Verify there is no power at the battery connection.
  - 4-4. Unplug all the wires and reconnect. Re-check the wiring on the battery is done correctly. Refer to the installation manual (3.2 Cable connection).
  - 4-5. Turn on the disconnect switch first, then Turn on the Circuit breaker.
5. If the battery set up is correctly done, but if the battery still does not operate, turn off the Circuit Breaker.
6. Turn off the disconnect switch.
7. Contact LGC regional contact point.

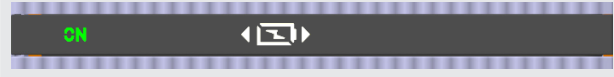
LED Status	Action
	Power on, Idle
	Charging
	Discharging

### If the battery FAULT LED is ON

1. Check if the inverter recognizes the battery. Refer to the inverter's troubleshooting guide on the battery set-up instruction.
2. Read the battery's fault ID through the inverter monitoring program via PC. Refer to the inverter's troubleshooting guide for instruction.
  - 2-1. Send the fault ID to LGC regional contact point.
  - 2-2. Turn off the Circuit Breaker.
  - 2-3. Turn off the disconnect switch.
  - 2-4. Wait further instruction from LGC.

LED Status	Action
	Fault

# 6 Uninstallation & Return

## 6.1 Return/replacement instructions

### 6.1.1 Uninstallation from the wall

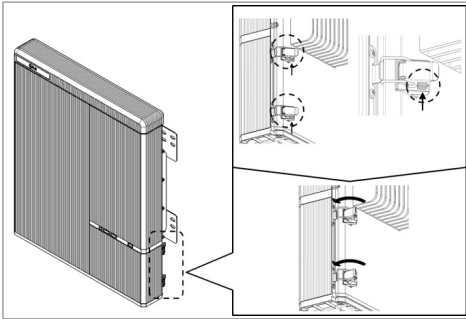

1. Switch OFF the Inverter before starting the uninstallation of the battery pack.

When the inverter operate (switch on/off), installer must follow the installation guide for the inverter

2. Press the two buttons and pull the two latches (marked position) on the rear.

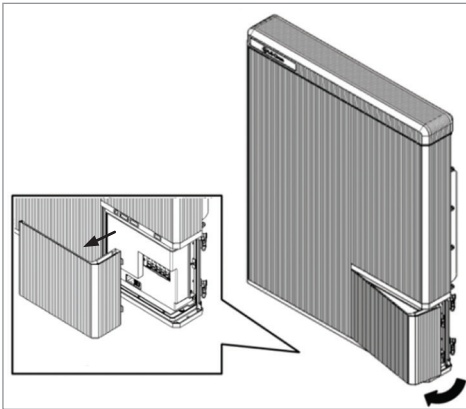

3. Open the wiring box cover (about 2~10 degrees), and pull to remove it.

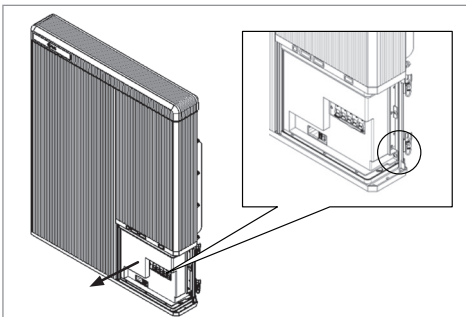

4. Switch off the circuit breaker and make sure that is in the OFF position. After that turn off the disconnect switch. (After the circuit breaker is turned off, The disconnect switch will automatically trip after 60 seconds.)

5. Loosen the screw (marked position), and remove the transparent protection cover.

#### CAUTION

MUST follow the turn off procedure. and do not turn off the disconnect switch while the battery is in operation.



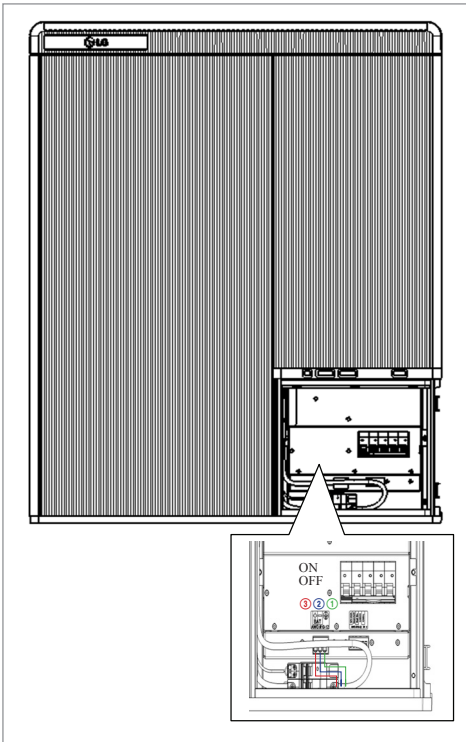

6. Check for voltage at power cable terminal.
7. Disconnect the communication cable from the communication port.
8. Disconnect the power cable connector from the terminal block.

Disconnect the positive terminal (+) ① first, and next the negative terminal (-) ② and finally ground terminal. ③

9. Disassembly power cable terminal.
10. Assemble transparent protection cover. Close the wiring box cover, and lock the ratchet.

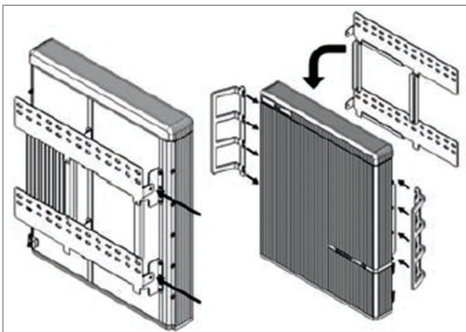

11. Loosen the two hex-socket screws using a socket wrench to detach the battery pack from the wall using lift handles.

**⚠ CAUTION**

According to regional regulations, several people may be required for moving equipment.

12. Repack in Box (See 3.1.1)

### 6.1.2 Contact information

Damaged batteries are dangerous and must be handled with extreme caution. They are not fit for use and may pose a danger to people or property. If the battery pack seems to be damaged, contact LGC regional contact point or your distributor. Use the contacts below for technical assistance. These phone numbers are available only during business hours on weekdays.

<b>Service Contact</b>		
<b>HQ (KOR) / Other Regions</b>	Address	29, Gwahaksaneop-3-ro, Oksan-myeon, Heungdeok-gu, Cheongju-si , Chungcheongbuk -do, South Korea
	E-mail	essservice@lgchem.com
<b>US</b>	Address	1064 Chicago Rd, Troy, MI 48083, USA
	Telephone	+1 888 375 8044
	E-mail	CSNorthAmericaESS@lgchem.com
<b>Europe</b>	Address	Otto-Volger Str. 7C 65843 Sulzbach (Taunus), Germany
	Telephone	+49 6196 5719 660
	E-mail	techcentereu@lgchem.com
<b>Australia</b>	Address	Unit 12/35 Dunlop Road, Mulgrave, 3170, Victoria, Australia
	Telephone	+61 1300 178 064
	E-mail	essserviceau@lgchem.com

## 7 Maintenance

Check sealing components [ex)gasket, sealing foam, silicon, etc] (p.23 no9) every half year for IP 55



Keep this manual for later use.

---

© 2018 LG Chem ESS Battery Division  
LG Guanghaiwamun Building, 58, Saemunan-ro, Jongno-gu, Seoul, 03184, Korea  
<http://www.lgesspartner.com> <http://www.lgchem.com>

